

# VA 20

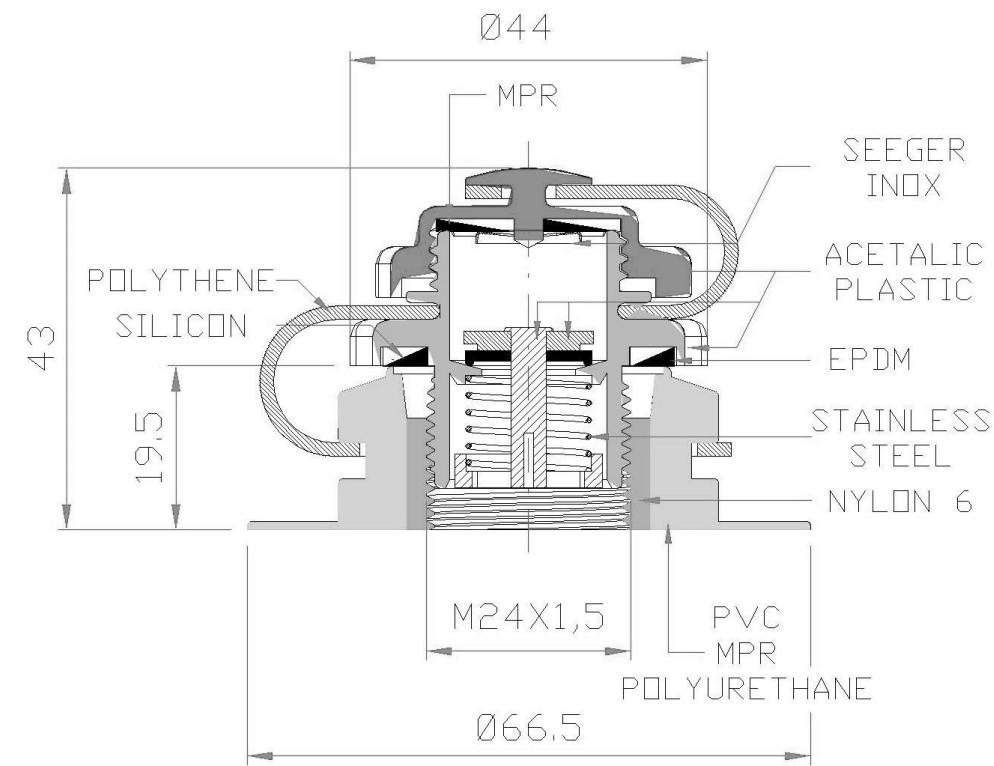

# VA 240

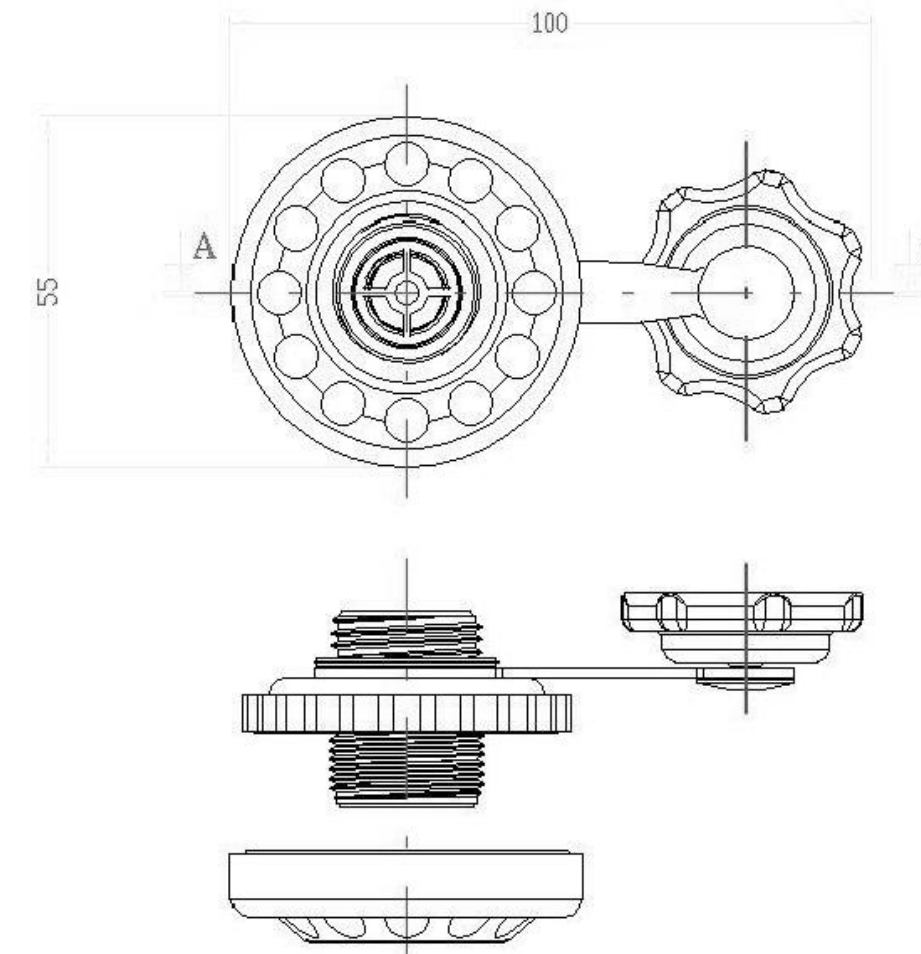

# VA 21

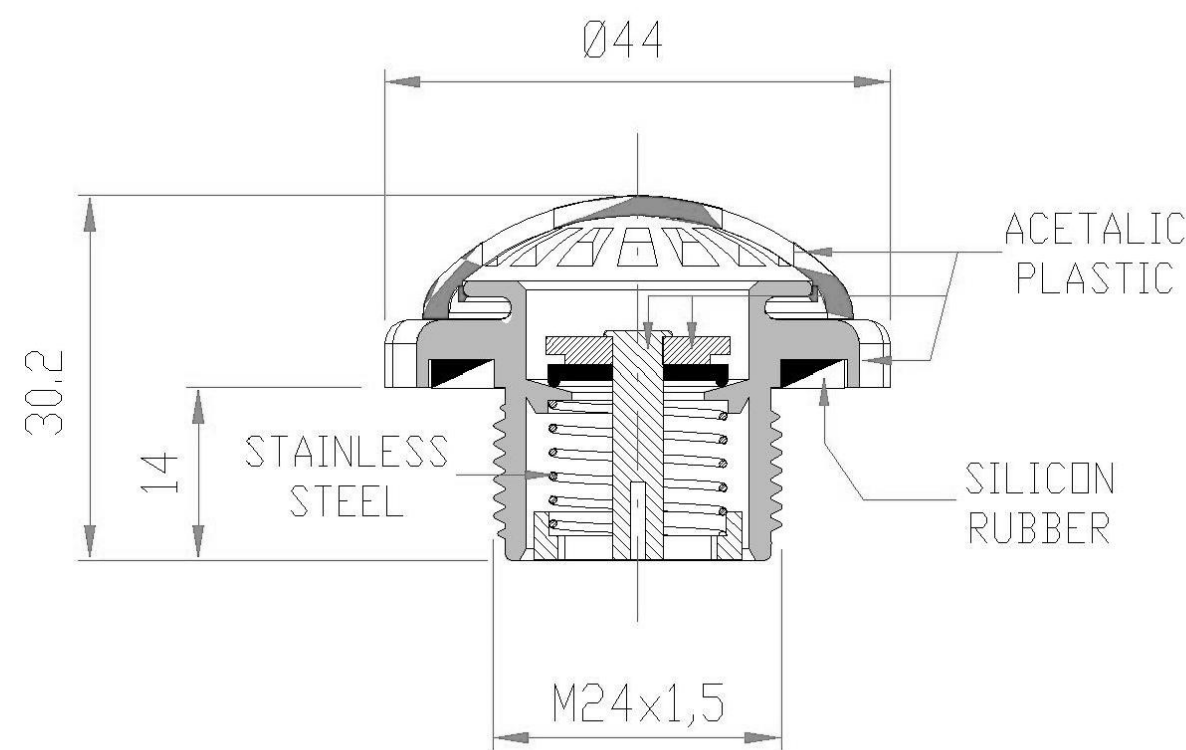

### INSTALLATION

- HOLE REQUIRED FOR VALVE INSTALLATION :  
a) VA20=Ø28±0,5 mm b) VA21 & VA240 = Ø23±0,5.
- TIGHTENING TORQUE = 30 Nm  
THE VALVE ASSEMBLY SHOULD BE RE-TORQUE ATLEAST AFTER HOURS
- THE USERS RESPONSIBILITY TO ENSURE THAT ANY FLUIDS USED DURING THE INSTALLATION OR OPERATION ARE COMPATIBLE WITH THIS VALVE
- PRESSURE SETTING AVAILABLE IN THE TABLE ATTACHED

### APPLICABLE STANDARD

ISO 15738:2002(E)

| VA240   | VA20    | VA21     | Calibration | Colour         | Opening | Closing |
|---------|---------|----------|-------------|----------------|---------|---------|
| A101242 | A101027 | A101170N | 60/25       | bianco/white   | 60      | 25      |
| A101239 | A101023 | A101160N | 80/50       | rosa/pink      | 80      | 50      |
| A101243 | A101021 | A101150N | 100/65      | verde/green    | 100     | 65      |
| A101241 | A101020 | A101140N | 180/135     | giallo/yellow  | 180     | 135     |
| A101249 | A101025 | A101130N | 200/150     | oro/gold       | 200     | 150     |
| A101246 | A101022 | A101120N | 225/170     | blu/blue       | 225     | 170     |
| A101240 | A101024 | A101110N | 240/185     | rosso/red      | 240     | 185     |
| A101238 | A101028 | A101100N | 260/200     | arancio/orange | 260     | 200     |
| -       | -       | A101180N | 350/300     | nero/black     | 350     | 300     |

|   |                   |                              |                     |                |               |
|---|-------------------|------------------------------|---------------------|----------------|---------------|
| Revisione   |                   |                              |                     |                |               |
| 01  | Titolo            |                              |                     |                | 21/02/22      |
| Progettato<br>GG  | Controllato<br>AA | Cod. Componente<br>see table | Data<br>15/01/2021  | Materiale      | Massa         |
|  <b>SCOPREGA</b> |                   |                              | VA240 - VA20 - VA21 |                |               |
| A1XXXXXX  |                   |                              |                     | Edizione<br>01 | Foglio<br>1/1 |